

Millennium Portable Water Cart

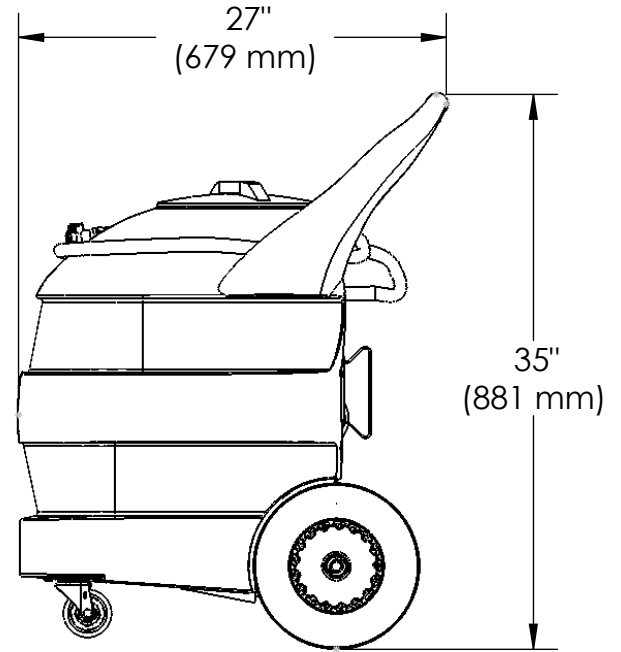
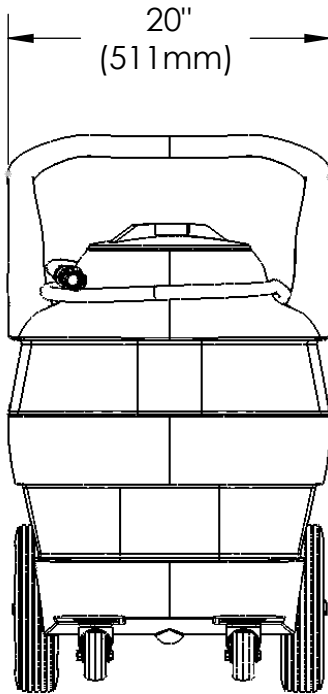

BA-MS-105: 75 Lbs. DC Cart with 100 - 120 VAC Charger

BA-MS-106: 75 Lbs. DC Cart with 100 - 240 VAC Charger and CE Marking

BA-MS-205: 54 Lbs. AC Cart, 100 - 120 VAC

Note: Cart weight is dry with no box or skid.